



**FRAMECAD™ Factory**  
99 Felton Mathew Avenue, Glen Innes  
Auckland 1072, New Zealand  
649-307-0411  
[www.framecad.com](http://www.framecad.com)  
[info@framecad.com](mailto:info@framecad.com)

### 1.0 Subject

*FrameCAD™ Cold-Formed Steel Load-Bearing & Nonload Bearing Studs and Tracks*

### 2.0 Research Scope

#### 2.1 Building Codes:

2006 International Building Code® (IBC)

2006 International Residential Code® (IRC)

#### 2.2 Properties Evaluated:

Structural Performance

### 3.0 Description

3.1 General – FrameCAD™ cold-formed steel studs and tracks in the product sizes specified in this report are to be used for exterior and interior applications in either load-bearing or nonload-bearing applications. The studs and tracks are factory formed from coils of galvanized light-gauge steel that complies with ASTM A 1003 Nonstructural Grade 33 (NS33) for nonload-bearing studs, ASTM A 1003 Structural Grade 33 Type H (ST33H), or ASTM A 653 SS Grade 33. Material 0.0538 inches (54 mils) thick or greater are formed from ASTM A 1003 Structural Grade 50 Type H (ST50H) or ASTM A 653 SS Grade 50, Class 1 or 3. The steel is hot-dipped galvanized with a minimum G60 (Z180) coating for load bearing applications and G40 (Z120) for non-load bearing applications.

3.2 The studs are manufactured with or without web punchouts. When punchouts are provided, they are located along the center of the web with a maximum width of 1½ inches (38 mm) and a maximum length of 4½ inches (114 mm). The punchouts are spaced at a minimum of 24 inches (610 mm) on center. The edge of the punchouts must be a minimum of 10 inches (254 mm) from each end of the stud.

3.3 The tracks have the same shape as the studs, except the stiffener lip of the track is removed at the location of each stud.

3.4 Refer to Table 1 for recognized product designations, properties, and values.

### 4.0 Installation

Installation shall be in accordance with the code requirements and referenced AISI standards therein for cold-formed steel light-frame construction, including: IBC Section 2210 and IRC Section R603 for One- And Two-Family Dwellings regulated by the 2006 IRC.

### 5.0 Performance

5.1 Nonload-bearing wall heights are determined by the lesser of the limiting conditions which include wall deflection, flexural strength, shear, and web crippling of the stud.

5.2 Allowable wall heights for interior nonload-bearing walls are shown in Table 11.

5.3 Allowable wall heights for curtain walls are shown in Table 12.

5.4 Load-bearing conditions must be checked for stud member end reactions (resulting from allowable heights and loads) and for web crippling per the accompanying tables.

### 6.0 Supporting Evidence

6.1 Structural Calculations of the product in accordance with the North American Specification for the Design of Cold-Formed Steel Structural Members (AISI NASPEC-2001 with 2004 Supplement) signed and sealed by a professional engineer, dated August 26, 2008.

6.2 Quality control manual in accordance with ICC-ES Acceptance Criteria for Quality Control Manuals, AC10, effective March 1, 2009.

### 7.0 Conditions of Use

FrameCAD Solutions™ steel studs and track identified in this report are deemed to comply with the referenced building codes subject to the following conditions:

7.1 All designs and calculations shall be prepared by a licensed design professional according to the requirements of the jurisdiction in which the project is located.

7.2 Jobsite manufacturing of studs or tracks is outside the scope of this report.

7.3 Wall studs subjected to lateral loads not tabulated shall be designed using the section properties per this report and the AISI Specification.

#### **8.0 Identification**

FrameCAD Solutions™ studs and track produced in accordance with this report shall be identified with labeling located on the web member at 48 inches on center that includes the following information:

8.1 The manufacturers name and/or logo.

8.2 The size and member designation of the individual part and to include the minimum uncoated base metal thickness, the minimum yield strength if greater than 33 ksi, the coating designation, and the production run date.

8.3 The ATI Code Compliance Research Report Number (CCRR-0130).

8.4 The mark of the independent inspection agency, NAHB Research Center (AAA-663).

#### **9.0 Code Compliance Research Report Use**

9.1 Approval of building products and/or materials can only be granted by a building official having legal authority in the specific jurisdiction where approval is sought.

9.2 Code Compliance Research Reports shall not be used in any manner that implies an endorsement of the product or manufacturer by ATI.

9.3 Reference to the Architectural Testing internet web site address at [www.archtest.com](http://www.archtest.com) is recommended to ascertain the current version and status of this report.

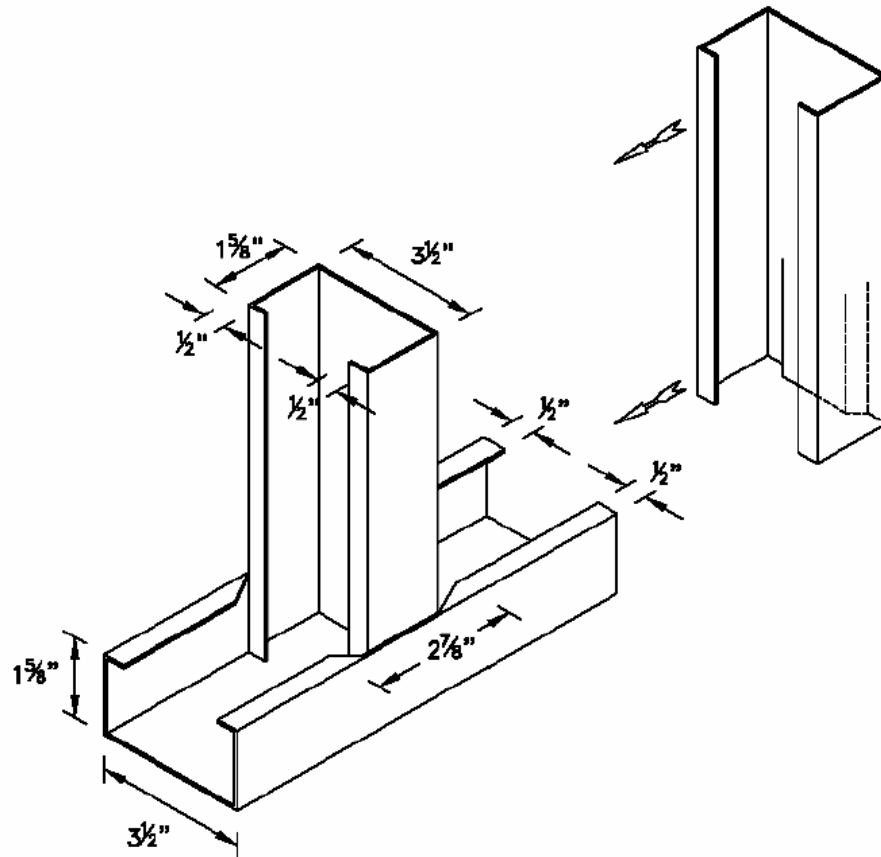

**Figure 1 - Typical Stud & Track Detail**  
(3 1/2" Stud Shown)

**TABLE 1— METAL THICKNESS**

Thickness Designation (mils)	Minimum Base Metal Thickness <sup>1</sup> (inch) [mm]	Design Thickness (inch) [mm]	Reference Gage
27	0.0269 [0.68]	0.0283 [0.72]	22
33	0.0329 [0.84]	0.0346 [0.88]	20
43	0.0428 [1.09]	0.0451 [1.15]	18
54	0.0538 [1.37]	0.0566 [1.44]	16
68	0.0677 [1.72]	0.0713 [1.81]	14

For SI: 1 inch = 25.4 mm, 1 mil = 25.4 x 10<sup>-3</sup> mm.

<sup>1</sup> Minimum thickness represents 95 percent of the design thickness and is the minimum acceptable thickness of base metal delivered to the jobsite.

**TABLE 2 — MEMBER DESIGNATION**

Member Designation	Minimum Web Depth <sup>1</sup> (inch)	Minimum Flange Width (inch)	Minimum Lip Size <sup>1</sup> (inch)	Max. Hole Size (inch)	Min. Steel Yield Strength (ksi)
350S162-27	3.50	1.625	0.50	1.5 x 4.5	33
350S162-33					33
350S162-43					33
350S162-54					50
350S162-68					50
550S162-33	5.50	1.625	0.50		33
550S162-43					33
550S162-54					50
550S162-68					50
600S162-33	6.00	1.625	0.50		33
600S162-43					33
600S162-54					50
600S162-68					50
350T162-27	3.50	1.625	0.50		33
350T162-33					33
350T162-43					33
350T162-54					50
350T162-68					50
550T162-33	5.50	1.625	0.50		33
550T162-43					33
550T162-54				50	
550T162-68				50	
600T162-33	6.00	1.625	0.50	33	
600T162-43				33	
600T162-54				50	
600T162-68				50	

For SI: 1 inch = 25.4 mm, 1 ksi = 6.89 MPa  
 Track stiffeners (lips) are removed at stud locations.

**Notes for Section Property Tables (Tables 3 through 8):**

1. When provided, factory punch-outs shall be located along the centerline of the webs of the members, have a minimum center-to-center spacing of 24", a maximum width of half the member depth or 1-1/2", whichever is less, and a maximum length of 4-1/2". The minimum distance between the end of the member and the near edge of the web punch-out shall be no less than 10".
2. The strength increase due to cold work of forming was incorporated for flexural strength as applicable in accordance with Section A7.2 of the 2001 NASPEC w/Supplement 4.
3. Minimum thickness represents 95% of the design thickness in accordance with Section A2.4 of the 2001 NASPEC.
4. The centerline bend radius is the greater of 2 times the design thickness or 3/32".
5. Tabulated gross properties are based on the full un-reduced cross section of the studs, away from the punchouts.
6. For deflection calculations, use the effective moment of inertia.
7. Definitions of structural property symbols:

**Gross Properties**

Area: The cross sectional area of the full un-reduced cross-section of the studs, away from the punchouts.

Weight: The weight per foot of the full un-reduced cross-section of the studs, away from the punchouts.

Ixx: Moment of inertia of the gross section about the strong axis (X-X).

Rx: Radius of gyration of the gross section about the X-X axis.

Sxx: Gross section-modulus about the strong axis (X-X).

Iyy: Moment of inertia of the gross section about the weak axis (Y-Y).

Ry: Radius of gyration of the gross section about the Y-Y axis.

Syy: Gross section-modulus about the strong axis (Y-Y).

**Effective Properties**

Ixx: Moment of inertia for deflection calculations based on "Procedure 1 for Serviceability Determination" of the 2001 NASPEC w/Supplement 4.

Sxx: Effective section modulus about the strong axis (X-X) at stress =  $F_y$ .

Ma: Allowable bending moment based on the effective section modulus and the allowable stress including the strength increase due to cold work of forming where applicable.

Va: Allowable shear load.

Ycg: Maximum distance from the outside of the compression flange to the center of gravity of the effective section.

**Torsional Properties**

J: St. Venant Torsional Constant

Cw: Torsional warping constant.

Xo: Distance from the shear center to the centroid along the principal X-axis.

Ro: Polar radius of gyration about the centroidal principal axis.

$\beta$ :  $1 - (X_o/R_o)^2$

**TABLE 3 — LOAD BEARING STUD (S) GROSS SECTION PROPERTIES**

Member Designation	Design Thickness (in)	Gross Section Properties						
		Area (in <sup>2</sup> )	Weight (lb/ft)	I <sub>xx</sub> (in <sup>4</sup> )	S <sub>xx</sub> (in <sup>3</sup> )	R <sub>x</sub> (in)	I <sub>yy</sub> (in <sup>4</sup> )	R <sub>y</sub> (in)
350S162-27	0.0283	0.211	0.72	0.417	0.196	1.406	0.081	0.619
350S162-33	0.0346	0.258	0.88	0.508	0.290	1.404	0.098	0.617
350S162-43	0.0451	0.334	1.14	0.654	0.374	1.400	0.125	0.612
350S162-54	0.0566	0.415	1.41	0.804	0.460	1.392	0.152	0.606
350S162-68	0.0713	0.515	1.75	0.985	0.563	1.383	0.184	0.597
550S162-33	0.0346	0.327	1.11	1.458	0.530	2.112	0.113	0.589
550S162-43	0.0451	0.424	1.44	1.883	0.685	2.107	0.145	0.584
550S162-54	0.0566	0.528	1.80	2.324	0.845	2.098	0.176	0.577
550S162-68	0.0713	0.657	2.24	2.861	1.040	2.086	0.212	0.568
600S162-33	0.0346	0.344	1.17	1.793	0.598	2.282	0.116	0.581
600S162-43	0.0451	0.447	1.52	2.316	0.772	2.276	0.148	0.576
600S162-54	0.0566	0.556	1.89	2.860	0.953	2.267	0.180	0.570
600S162-68	0.0713	0.693	2.36	3.525	1.175	2.255	0.218	0.560

For SI: 1 inch = 25.4 mm, 1 lb/ft = 14.5939 N/m

**TABLE 4 — STUD (S) EFFECTIVE SECTION PROPERTIES**

Member Designation	Design Thickness (in)	Effective Properties, F <sub>y</sub> =33 ksi					Effective Properties, F <sub>y</sub> =50 ksi				
		I <sub>xx</sub> (in <sup>4</sup> )	S <sub>xx</sub> (in <sup>3</sup> )	M <sub>a</sub> (in-k)	V <sub>a</sub> (lb)	V <sub>anet</sub> (lb)	I <sub>xx</sub> (in <sup>4</sup> )	S <sub>xx</sub> (in <sup>3</sup> )	M <sub>a</sub> (in-k)	V <sub>a</sub> (lb)	V <sub>anet</sub> (lb)
350S162-27	0.0283	0.419	0.239	3.86	614	359	N/A				
350S162-33	0.0346	0.508	0.257	5.08	1024	487					
350S162-43	0.0451	0.654	0.357	7.05	1739	631					
350S162-54	0.0566	N/A					0.804	0.426	12.74	3372	947
350S162-68	0.0713	N/A					0.985	0.549	16.44	4202	897
550S162-33	0.0346	1.458	0.512	10.11	699	699	N/A				
550S162-43	0.0451	1.883	0.681	14.79	1550	1199					
550S162-54	0.0566	N/A					2.324	0.811	26.86	3093	1881
550S162-68	0.0713	N/A					2.861	1.031	34.94	5350	2532
600S162-33	0.0346	1.793	0.577	11.41	638	638	N/A				
600S162-43	0.0451	2.316	0.767	16.68	1416	1240					
600S162-54	0.0566	N/A									
600S162-68	0.0713	N/A					3.525	1.164	39.47	5350	2879

For SI: 1 inch = 25.4 mm, 1 inch-kips = 12.8 N-m, 1 lb = 4.448 N

**TABLE 5 — LOAD BEARING STUD (S) TORSIONAL PROPERTIES**

Member Designation	Design Thickness (in)	Torsional Properties				
		$J \times 1000$ (in <sup>4</sup> )	$C_w$ (in <sup>6</sup> )	$X_o$ (in)	$R_o$ (in)	$\beta$
350S162-27	0.0283	0.056	0.243	-1.362	2.052	0.560
350S162-33	0.0346	0.103	0.273	-1.351	2.044	0.563
350S162-43	0.0451	0.227	0.345	-1.339	2.031	0.565
350S162-54	0.0566	0.443	0.418	-1.331	2.019	0.566
350S162-68	0.0713	0.872	0.503	-1.321	2.004	0.565
550S162-33	0.0346	0.130	0.704	-1.134	2.468	0.789
550S162-43	0.0451	0.288	0.894	-1.123	2.458	0.791
550S162-54	0.0566	0.564	1.088	-1.114	2.445	0.792
550S162-68	0.0713	1.114	1.316	-1.103	2.427	0.793
600S162-33	0.0346	0.137	0.851	-1.091	2.595	0.823
600S162-43	0.0451	0.303	1.082	-1.081	2.585	0.825
600S162-54	0.0566	0.594	1.318	-1.072	2.572	0.826
600S162-68	0.0713	1.174	1.596	-1.061	2.554	0.828

For SI: 1 inch = 25.4 mm.

**TABLE 6 — TRACK (T) GROSS SECTION PROPERTIES**

Member Designation	Design Thickness (in)	Gross Section Properties						
		Area (in <sup>2</sup> )	Weight (lb/ft)	$I_{xx}$ (in <sup>4</sup> )	$S_{xx}$ (in <sup>3</sup> )	$R_x$ (in)	$I_{yy}$ (in <sup>4</sup> )	$R_y$ (in)
350T162-27	0.0283	0.180	0.64	0.345	0.197	1.399	0.050	0.517
350T162-33	0.0346	0.228	0.78	0.446	0.255	1.397	0.061	0.516
350T162-43	0.0451	0.297	1.01	0.575	0.329	1.392	0.076	0.514
350T162-54	0.0566	0.370	1.26	0.712	0.407	1.387	0.097	0.513
350S162-68	0.0713	0.462	1.57	0.972	0.518	1.450	0.099	0.462
550T162-33	0.0346	0.298	1.01	1.280	0.467	2.074	0.069	0.481
550T162-43	0.0451	0.387	1.32	1.658	0.603	2.070	0.089	0.480
550T162-54	0.0566	0.483	1.65	2.058	0.748	2.064	0.110	0.478
550S162-68	0.0713	0.605	2.06	2.699	0.939	2.112	0.110	0.427
600S162-33	0.0346	0.311	1.06	1.590	0.517	2.260	0.057	0.426
600S162-43	0.0451	0.405	1.38	2.072	0.673	2.261	0.073	0.424
600S162-54	0.0566	0.509	1.73	2.611	0.843	2.266	0.091	0.422
600S162-68	0.0713	0.641	2.18	3.309	1.059	2.273	0.113	0.419

For SI: 1 inch = 25.4 mm, 1 lb/ft = 14.5939 N/m.

**TABLE 7— TRACK (T) EFFECTIVE SECTION PROPERTIES**

Member Designation	Design Thickness (in)	Effective Properties, Fy =33 ksi					Effective Properties, Fy =50 ksi				
		I <sub>xx</sub> (in <sup>4</sup> )	S <sub>xx</sub> (in <sup>3</sup> )	M <sub>a</sub> (in-k)	V <sub>a</sub> (lb)	Y <sub>cg</sub> (in)	I <sub>xx</sub> (in <sup>4</sup> )	S <sub>xx</sub> (in <sup>3</sup> )	M <sub>a</sub> (in-k)	V <sub>a</sub> (lb)	Y <sub>cg</sub> (in)
350T162-27	0.0283	0.272	0.125	2.50	613	2.071	N/A				
350T162-33	0.0346	0.358	0.164	3.24	1024	2.034					
350T162-43	0.0451	0.494	0.231	4.57	1739	1.979					
350T162-54	0.0566	N/A					0.678	0.291	8.71	3372	1.968
350T162-68	0.0713						0.919	0.428	12.81	4838	2.007
550T162-33	0.0346	1.076	0.302	5.96	699	3.185	N/A				
550T162-43	0.0451	1.456	0.455	8.99	1550	3.019					
550T162-54	0.0566	N/A					1.823	0.572	17.14	3093	3.007
550T162-68	0.0713						2.569	0.804	24.07	5468	3.029
600T162-33	0.0346	1.385	0.335	6.61	597	3.569	N/A				
600T162-43	0.0451	1.868	0.534	10.55	1321	3.321					
600T162-54	0.0566	N/A					2.374	0.678	20.30	2617	3.327
600T162-68	0.0713						3.154	0.913	27.34	5251	3.282

For SI: 1 inch = 25.4 mm, 1 inch-kips = 12.8 N-m, 1 lb = 4.448 N

**TABLE 8 — TRACK (T) TORSIONAL PROPERTIES**

Member Designation	Design Thickness (in)	Torsional Properties				
		J x1000 (in <sup>4</sup> )	C <sub>w</sub> (in <sup>6</sup> )	X <sub>o</sub> (in)	R <sub>o</sub> (in)	β
350T150-27	0.0283	0.050	0.106	-0.996	1.793	0.692
350T150-33	0.0346	0.091	0.129	-0.994	1.791	0.692
350T150-43	0.0451	0.201	0.165	-0.991	1.785	0.692
350T150-54	0.0566	0.395	0.203	-0.991	1.780	0.692
350T162-68	0.0713	0.799	0.256	-0.852	1.779	0.771
550T150-33	0.0346	0.119	0.372	-0.822	2.283	0.870
550T150-43	0.0451	0.262	0.478	-0.819	2.277	0.870
550T150-54	0.0566	0.516	0.591	-0.818	2.271	0.870
550T162-68	0.0713	1.025	0.652	-0.710	2.269	0.902
600T162-33	0.0346	0.124	0.389	-0.691	2.401	0.917
600T162-43	0.0451	0.275	0.503	-0.687	2.400	0.918
600T162-54	0.0566	0.543	0.630	-0.684	2.404	0.919
600T162-68	0.0713	1.086	0.794	-0.680	2.409	0.920

For SI: 1 inch = 25.4 mm.

**TABLE 9 — ALLOWABLE WEB CRIPPLING LOAD (lbs) – SINGLE MEMBERS<sup>1,2,3</sup>**

Stud Designation	Yield Strength (ksi)	Condition 1 Bearing Length (in.)		Condition 2 Bearing Length (in.)		Condition 3 Bearing Length (in.)		Condition 4 Bearing Length (in.)	
		1	3.5	1	3.5	1	3.5	1	3.5
350S162-33	33	166	260	324	445	131	175	384	484
350S162-43	33	278	428	571	768	240	315	680	842
350S162-54	50	637	967	1331	1761	594	768	1645	2005
350S162-68	50	965	1441	2047	2660	970	1232	2631	3159
550S162-33	33	155	243	315	432	100	134	339	428
550S162-43	33	262	405	556	749	195	256	614	760
550S162-54	50	606	920	1302	1722	502	649	1508	1838
550S162-68	50	923	1380	2007	2608	844	1071	2441	2931
600S162-33	33	153	240	313	430	93	125	329	416
600S162-43	33	259	400	553	745	185	243	600	743
600S162-54	50	599	909	1295	1713	482	623	1478	1802
600S162-68	50	914	1366	1998	2596	816	1036	2399	2881

For SI: 1 inch = 25.4 mm, 1 lb. = 4.448 N.

<sup>1</sup> For multiple members, multiply the listed capacity of a single member by the number of members in the assembly

<sup>2</sup> Values shown are for un-punched and punched members. For punched members, the clear distance between the edge of bearing and the edge of the punchout shall be at least two times the depth of the web to a maximum of 10 inches,

<sup>3</sup> Condition 1 – End Reaction – One Flange Loading  
 Condition 2 – Interior Reaction – One Flange Loading  
 Condition 3 – End Reaction – Two Flange Loading  
 Condition 4 – Interior Reaction – Two Flange Loading

Refer to Section C3.4 of the Commentary on the North American Specification for the Design of Cold-Formed Steel Structural Members (2001 NASPEC w/Supplement 4).

**TABLE 10 - ALLOWABLE WEB CRIPPLING LOAD (lbs)**  
**BACK-TO-BACK MEMBERS** <sup>1,2,3</sup>

Member Designation	Min. Yield Strength (ksi)	Condition 1 Bearing Length (in.)		Condition 2 Bearing Length (in.)		Condition 3 Bearing Length (in.)		Condition 4 Bearing Length (in.)	
		1	3.5	1	3.5	1	3.5	1	3.5
350S162-33	33	776	1182	1090	1443	463	585	984	1241
350S162-43	33	1272	1901	1861	2414	838	1037	1808	2239
350S162-54	50	2867	4217	4313	5500	2062	2514	4459	5436
350S162-68	50	4286	6196	6614	8294	3346	4018	7236	8689
550S162-33	33	774	1179	1087	1439	384	484	815	1028
550S162-43	33	1269	1897	1857	2409	721	893	1556	1927
550S162-54	50	2861	4208	4304	5488	1818	2217	3933	4794
550S162-68	50	4278	6185	6601	8278	3008	3612	6506	7812
600S162-33	33	774	1178	1086	1438	366	462	778	982
600S162-43	33	1268	1896	1856	2408	696	862	1501	1859
600S162-54	50	2860	4207	4302	5486	1765	2152	3818	4654
600S162-68	50	4276	6182	6599	8275	2935	3524	6347	7621

For SI: 1 inch = 25.4 mm, 1 lb. = 4.448 N.

<sup>1</sup> For back-to-back members, the distance between the web connectors and the flange shall be kept to a minimum.

<sup>2</sup> Values shown are for unfastened supports, un-punched and punched members. For punched members, the clear distance between the edge of bearing and the edge of the punchout shall be at least two times the depth of the web to a maximum of 10 inches,

<sup>3</sup> Condition 1 – End Reaction – One Flange Loading  
Condition 2 – Interior Reaction – One Flange Loading  
Condition 3 – End Reaction – Two Flange Loading  
Condition 4 – Interior Reaction – Two Flange Loading  
Refer to Section C3.4 of the Commentary on the North American Specification for the Design of Cold-Formed Steel Structural Members (2001 NASPEC w/Supplement 4).

**TABLE 11 —LIMITING WALL HEIGHTS – INTERIOR NONLOAD-BEARING WALLS  
(NON-COMPOSITE<sup>1,2</sup>)**

Stud Designation	Min. F <sub>y</sub> (ksi)	Stud Spacing (in) o.c.	Lateral Load					
			5 psf		7.5 psf		10 psf	
			Deflection Limit					
			L/120	L/240	L/120	L/240	L/120	L/240
350S162-27	33	16	19' 8"	16' 0"	16' 0"	14' 0"	13' 11"	12' 9"
		24	16' 0"	14' 0"	13' 1"	12' 3"	11' 4"	11' 1"
350S162-33		16	21' 6"	17' 1"	18' 5"	14' 11"	15' 11"	13' 7"
		24	18' 5"	14' 11"	14' 11"	13' 0"	13' 0"	11' 10"
350S162-43		16	23' 5"	18' 7"	20' 5"	16' 2"	18' 7"	14' 9"
		24	20' 5"	16' 2"	17' 10"	14' 2"	15' 4"	12' 10"
550S162-33		16	30' 7"	24' 3"	26' 0"	21' 2"	22' 6"	19' 3"
		24	25' 11"	21' 2"	21' 2"	18' 6"	18' 4"	16' 10"
550S162-43		16	33' 3"	26' 5"	29' 1"	23' 1"	26' 5"	20' 11"
		24	29' 1"	23' 1"	25' 5"	20' 2"	22' 2"	18' 4"
600S162-33		16	32' 9"	26' 0"	27' 6"	22' 8"	23' 11"	20' 7"
		24	27' 6"	22' 8"	22' 6"	19' 10"	19' 6"	18' 1"
600S162-43		16	35' 8"	28' 4"	31' 2"	24' 9"	28' 4"	22' 5"
		24	31' 2"	24' 9"	27' 2"	21' 7"	23' 6"	19' 7"

For SI: 1 inch = 25.4 mm, 1 psf = 48 Pa.

<sup>1</sup> Limiting wall heights based on continuous lateral support of each flange over the full length of the stud.

<sup>2</sup> Heights based on steel stud properties only.

**Notes for Table 12 – Limiting Wall Heights – Curtain Wall:**

For SI: 1 inch = 25.4 mm, 1 psf = 48 Pa.

<sup>1</sup> All values are based on steel stud properties only and steel yield strength of 33 ksi for 33 and 43 mil steel and 50 ksi for 54 mil and 68 mil steel. Thicknesses for each member are set in Table forth in Tables 1 and 2.

<sup>2</sup> End reactions for web crippling shall be checked.

<sup>3</sup> Values in table are based on continuous lateral support of each flange over the full length of the stud.

<sup>4</sup> A 0.7 factor has been applied to lateral loads for deflection calculation in accordance with IBC Table 1604.3, note f.

**TABLE 12 — LIMITING WALL HEIGHTS – CURTAIN WALL<sup>1,2,3,4</sup>**

Member Designation	Stud Spacing (in)	Lateral Load (Wind)											
		15 psf			20 psf			25 psf			30 psf		
		Deflection Limit											
		L/240	L/360	L/600	L/240	L/360	L/600	L/240	L/360	L/600	L/240	L/360	L/600
350S162-33	12	14' 8"	12' 10"	10' 10"	13' 0"	11' 8"	9' 10"	11' 8"	10' 10"	9' 2"	10' 8"	10' 2"	8' 7"
	16	13' 0"	11' 8"	9' 10"	11' 3"	10' 7"	8' 11"	10' 1"	9' 10"	8' 4"	9' 2"	9' 2"	7' 10"
	24	10' 8"	10' 2"	8' 7"	9' 2"	9' 2"	7' 10"	8' 3"	8' 3"	7' 3"	7' 6"	7' 6"	6' 10"
350S162-43	12	16' 0"	14' 0"	11' 9"	14' 6"	12' 8"	10' 8"	13' 6"	11' 9"	9' 11"	12' 6"	11' 1"	9' 4"
	16	14' 6"	12' 8"	10' 8"	13' 2"	11' 6"	9' 9"	11' 10"	10' 8"	9' 0"	10' 10"	10' 1"	8' 6"
	24	12' 6"	11' 1"	9' 4"	10' 10"	10' 1"	8' 6"	9' 8"	9' 4"	7' 11"	8' 10"	8' 10"	7' 5"
350S162-54	12	17' 1"	14' 11"	12' 7"	15' 6"	13' 7"	11' 5"	14' 5"	12' 7"	10' 7"	13' 7"	11' 10"	10' 0"
	16	15' 6"	13' 7"	11' 5"	14' 1"	12' 4"	10' 4"	13' 1"	11' 5"	9' 8"	12' 4"	10' 9"	9' 1"
	24	13' 7"	11' 10"	10' 0"	10' 9"	10' 9"	9' 1"	11' 5"	10' 0"	8' 5"	10' 9"	9' 5"	7' 11"
350S162-68	12	18' 3"	16' 0"	13' 5"	16' 7"	14' 6"	12' 3"	15' 5"	13' 5"	11' 4"	14' 6"	12' 8"	10' 8"
	16	16' 7"	14' 6"	12' 3"	15' 1"	13' 2"	11' 1"	14' 0"	12' 3"	10' 4"	13' 2"	11' 6"	9' 8"
	24	14' 6"	12' 8"	10' 8"	13' 2"	11' 6"	9' 8"	12' 3"	10' 8"	9' 0"	11' 6"	10' 0"	8' 6"
550S162-33	12	20' 11"	18' 3"	15' 5"	18' 4"	16' 7"	14' 0"	16' 5"	15' 5"	13' 0"	15' 0"	14' 6"	12' 3"
	16	18' 4"	16' 7"	14' 0"	15' 11"	15' 1"	12' 8"	14' 3"	14' 0"	11' 9"	13' 0"	13' 0"	11' 1"
	24	15' 0"	14' 6"	12' 3"	13' 0"	13' 0"	11' 1"	11' 7"	11' 7"	10' 4"	10' 7"	10' 7"	9' 8"
550S162-43	12	22' 9"	19' 10"	16' 9"	20' 8"	18' 1"	15' 3"	19' 2"	16' 9"	14' 2"	18' 1"	15' 9"	13' 4"
	16	20' 8"	18' 1"	15' 3"	18' 9"	16' 5"	13' 10"	17' 2"	15' 3"	12' 10"	15' 8"	14' 4"	12' 1"
	24	18' 1"	15' 9"	13' 4"	15' 8"	14' 4"	12' 1"	14' 1"	13' 4"	11' 3"	12' 10"	12' 6"	10' 7"
550S162-54	12	24' 4"	21' 3"	17' 11"	22' 1"	19' 4"	16' 3"	20' 6"	17' 11"	15' 1"	19' 4"	16' 10"	14' 3"
	16	22' 1"	19' 4"	16' 3"	20' 1"	17' 7"	14' 10"	18' 8"	16' 3"	13' 9"	17' 7"	15' 4"	12' 11"
	24	19' 4"	16' 10"	14' 3"	17' 7"	15' 4"	12' 11"	16' 3"	14' 3"	12' 0"	15' 4"	13' 5"	11' 3"
550S162-68	12	26' 1"	22' 10"	19' 3"	23' 9"	20' 8"	17' 5"	22' 0"	19' 3"	16' 2"	20' 8"	18' 1"	15' 3"
	16	23' 9"	20' 8"	17' 5"	21' 6"	18' 10"	15' 10"	20' 0"	17' 5"	14' 9"	18' 10"	16' 5"	13' 10"
	24	20' 8"	18' 1"	15' 3"	18' 10"	16' 5"	13' 10"	17' 5"	15' 3"	12' 10"	16' 5"	14' 4"	12' 1"
600S162-33	12	22' 4"	19' 6"	16' 6"	19' 6"	17' 9"	15' 0"	17' 5"	16' 6"	13' 11"	15' 11"	15' 6"	13' 1"
	16	19' 6"	17' 9"	15' 0"	16' 11"	16' 2"	13' 7"	15' 1"	15' 0"	12' 8"	13' 9"	13' 9"	11' 11"
	24	15' 11"	15' 6"	13' 1"	13' 9"	13' 9"	11' 11"	12' 4"	12' 4"	11' 0"	11' 3"	11' 3"	10' 5"
600S162-43	12	24' 4"	21' 3"	17' 11"	22' 2"	19' 4"	16' 4"	20' 7"	17' 11"	15' 2"	19' 3"	16' 11"	14' 3"
	16	22' 2"	19' 4"	16' 4"	20' 1"	17' 7"	14' 10"	18' 3"	16' 4"	13' 9"	16' 8"	15' 4"	12' 11"
	24	19' 3"	16' 11"	14' 3"	16' 8"	15' 4"	12' 11"	14' 11"	14' 3"	12' 0"	13' 7"	13' 5"	11' 4"
600S162-54	12	26' 1"	22' 10"	19' 3"	23' 8"	20' 8"	17' 5"	22' 0"	19' 3"	16' 2"	20' 8"	18' 1"	15' 3"
	16	23' 8"	20' 8"	17' 5"	21' 6"	18' 10"	15' 10"	20' 0"	17' 5"	14' 9"	18' 10"	16' 5"	13' 10"
	24	20' 8"	18' 1"	15' 3"	18' 10"	16' 5"	13' 10"	17' 5"	15' 3"	12' 10"	16' 5"	14' 4"	12' 1"
600S162-68	12	28' 0"	24' 5"	20' 7"	25' 5"	22' 2"	18' 9"	23' 7"	20' 7"	17' 4"	22' 2"	19' 5"	16' 4"
	16	25' 5"	22' 2"	18' 9"	23' 1"	20' 2"	17' 0"	21' 5"	18' 9"	15' 9"	20' 2"	17' 7"	14' 10"
	24	22' 2"	19' 5"	16' 4"	20' 2"	17' 7"	14' 10"	18' 9"	16' 4"	13' 9"	17' 7"	15' 5"	13' 0"

**Notes for Combined Axial and Lateral Load Tables (Tables 13, 14, and 15):**

1. Allowable loads are based on weak axis and torsional bracing of 48" o.c. maximum for axial load calculation and continuous support of each flange for flexural calculation.
2. End reactions shall be checked for web crippling.
3. All 33 and 43 mil studs are 33-ksi steel while 54 mil and 68 mil studs are 50-ksi steel.
4. Allowable axial loads in kips per stud (1 kip=1000 lbs.)
5. Deflection exceeds L/120
6. Deflection exceeds L/240
7. Deflection exceeds L/360
8. Deflection exceeds L/600
9. Deflection exceeds L/720
10. If the tabulated load is not footnoted, deflection is less then L/720
11. 5 psf lateral loads shall not be used for wind load design.

**TABLE 13 – COMBINED AXIAL AND LATERAL LOAD TABLE FOR 350S162**

Wall Height (ft)	Max. Stud Spacing (in.)	350S162-																			
		Lateral Load (psf)																			
		5 psf <sup>11</sup>				15 psf				20 psf				25 psf				30 psf			
		Stud Thickness (mils)																			
		33	43	54	68	33	43	54	68	33	43	54	68	33	43	54	68	33	43	54	68
8	24	1.58	2.32	3.76	4.87	0.78	1.49	2.99	4.08	0.43 <sup>6</sup>	1.11 <sup>7</sup>	2.64	3.72	0.09 <sup>6</sup>	0.76 <sup>6</sup>	2.30 <sup>7</sup>	3.38		0.42 <sup>6</sup>	1.99 <sup>6</sup>	3.05
9		1.39	2.09	3.39	4.41	0.46 <sup>6</sup>	1.11 <sup>7</sup>	2.48	3.48	0.07 <sup>6</sup>	0.69 <sup>6</sup>	2.08 <sup>7</sup>	3.06		0.29 <sup>6</sup>	1.71 <sup>6</sup>	2.68 <sup>7</sup>			1.37 <sup>6</sup>	2.31 <sup>6</sup>
10		1.19	1.84	2.99	3.92	0.17 <sup>6</sup>	0.74 <sup>6</sup>	1.99 <sup>7</sup>	2.88		0.29 <sup>6</sup>	1.56 <sup>6</sup>	2.43 <sup>6</sup>			1.17 <sup>6</sup>	2.02 <sup>6</sup>			0.81 <sup>3</sup>	1.63 <sup>6</sup>
12		0.79 <sup>7</sup>	1.34	2.21	2.94		0.13 <sup>3</sup>	1.13 <sup>3</sup>	1.81 <sup>6</sup>			0.7 <sup>3</sup>	1.35 <sup>3</sup>			0.32 <sup>2</sup>	0.94 <sup>3</sup>				0.56 <sup>2</sup>
14		0.46 <sup>6</sup>	0.89 <sup>6</sup>	1.58 <sup>7</sup>	2.16			0.53 <sup>2</sup>	1.04 <sup>3</sup>			0.13 <sup>2</sup>	0.60 <sup>2</sup>			0.21 <sup>2</sup>					
16		0.21 <sup>3</sup>	0.54 <sup>3</sup>	1.12 <sup>6</sup>	1.57 <sup>6</sup>			0.13 <sup>2</sup>	0.51 <sup>2</sup>				0.11 <sup>2</sup>								

For SI: 1 inch = 25.4 mm, 1 lb. = 4.4448 N, 1 kip = 4448 N, 1 psf = 48 Pa.

**TABLE 14 - COMBINED AXIAL AND LATERAL LOAD TABLE FOR 550S162**

Wall Height (ft)	Max. Stud Spacing (in.)	550S162-																			
		Lateral Load (psf)																			
		5 psf				15 psf				20 psf				25 psf				30 psf			
		Stud Thickness (mils)																			
		33	43	54	68	33	43	54	68	33	43	54	68	33	43	54	68	33	43	54	68
8	24	2.28	3.27	5.52	7.34	1.77	2.77	5.06	6.86	1.52	2.53	4.83	6.63	1.28	2.29	4.60	6.39	1.04	2.06	4.38	6.16
9		2.19	3.16	5.42	7.26	1.54	2.54	4.82	6.64	1.23	2.24	4.53	6.33	0.93	1.94	4.24	6.03	0.65	1.65	3.96	5.74
10		2.07	3.04	5.24	7.16	1.29	2.28	4.50	6.36	0.93	1.91	4.14	5.98	0.58 <sup>7</sup>	1.56	3.80	5.61	0.24 <sup>6</sup>	1.22 <sup>7</sup>	3.46	5.24
12		1.81	2.75	4.79	6.59	0.76 <sup>7</sup>	1.69	3.74	5.45	0.30 <sup>6</sup>	1.22 <sup>7</sup>	3.27	4.93		0.77 <sup>6</sup>	2.82 <sup>7</sup>	4.44		0.35 <sup>6</sup>	2.39 <sup>6</sup>	3.97 <sup>7</sup>
14		1.49	2.38	4.21	5.84	0.24 <sup>6</sup>	1.08 <sup>6</sup>	2.91 <sup>7</sup>	4.40		0.53 <sup>6</sup>	2.35 <sup>6</sup>	3.78 <sup>6</sup>		0.02 <sup>3</sup>	1.83 <sup>6</sup>	3.21 <sup>3</sup>			1.35 <sup>3</sup>	2.67 <sup>6</sup>
16		1.16	1.98	3.56	4.98		0.51 <sup>3</sup>	2.10 <sup>6</sup>	3.35 <sup>6</sup>			1.50 <sup>3</sup>	2.69 <sup>6</sup>			0.96 <sup>3</sup>	2.08 <sup>6</sup>			0.46 <sup>2</sup>	1.52 <sup>3</sup>

For SI: 1 inch = 25.4 mm, 1 lb. = 4.4448 N, 1 kip = 4448 N, 1 psf = 48 Pa.

**TABLE 15 - COMBINED AXIAL AND LATERAL LOAD TABLE FOR 600S162**

Wall Height (ft)	Max. Stud Spacing (in.)	600S162-																			
		Lateral Load (psf)																			
		5 psf				15 psf				20 psf				25 psf				30 psf			
		Stud Thickness (mils)																			
		33	43	54	68	33	43	54	68	33	43	54	68	33	43	54	68	33	43	54	68
8	24	2.32	3.30	5.52	7.35	1.87	2.87	5.12	6.94	1.65	2.66	4.92	6.74	1.43	2.44	4.73	6.53	1.21	2.24	4.53	6.33
9		2.26	3.24	5.46	7.29	1.68	2.68	4.94	6.75	1.40	2.41	4.69	6.49	1.13	2.15	4.44	6.23	0.86	1.89	4.19	5.97
10		2.18	3.16	5.39	7.21	1.47	2.47	4.73	6.53	1.13	2.14	4.41	6.20	0.81	1.82	4.10	5.87	0.49 <sup>7</sup>	1.51	3.80	5.56
12		1.95	2.93	5.13	7.01	0.98	1.96	4.17	5.98	0.53 <sup>6</sup>	1.51	3.72	5.49	0.11 <sup>6</sup>	1.08 <sup>7</sup>	3.29	5.03		0.67 <sup>6</sup>	2.88 <sup>7</sup>	4.58
14		1.67	2.61	4.64	6.43	0.46 <sup>6</sup>	1.37 <sup>7</sup>	3.40	5.06		0.83 <sup>6</sup>	2.85 <sup>6</sup>	4.46		0.32 <sup>6</sup>	2.34 <sup>6</sup>	3.89 <sup>6</sup>			1.85 <sup>6</sup>	3.35 <sup>6</sup>
16		1.36	2.25	4.05	5.66		0.80 <sup>6</sup>	2.60 <sup>6</sup>	4.05 <sup>7</sup>		0.20 <sup>3</sup>	1.98 <sup>6</sup>	3.36 <sup>6</sup>			1.42 <sup>3</sup>	2.73 <sup>6</sup>			0.91 <sup>3</sup>	2.15 <sup>3</sup>

For SI: 1 inch = 25.4 mm, 1 lb. = 4.4448 N, 1 kip = 4448 N, 1 psf = 48 Pa.