



Code Compliance Research Report

CCRR-0135

Subject to Renewal: 3/4/2012

Visit www.archtest.com for current status

Issued: 2/8/2010

Page 1 of 7

GAF Decking Systems
9806 Lackman Road
Lenexa, Kansas 66219
(866)-322-7452

www.GAF.com

1.0 Subject

GAF/Elk Composite Building Products, Inc
Traditional Series – Hollow Core Guardrail System

2.0 Research Scope

2.1. Building codes:

- 2006 International Building Code (IBC)
- 2006 International Residential Code (IRC)
- 2009 International Building Code (IBC)
- 2009 International Residential Code (IRC)

2.2. Properties:

- Structural performance
- Durability
- Surface Burning

3.0 Description

3.1. General – *Traditional Series* Guardrail System is a guard or guardrail under the definitions of the referenced codes. It is intended for use at or near the open sides of elevated walking areas of buildings and walkways as required by the codes.

3.2. *Traditional Series* Guardrail System is a level guard with rail lengths up to 91 inches in length (measured from inside of support posts) and a maximum installed height of 42 inches. See Table 1.

3.3. *Traditional Series* Guardrail System is an assembly of extruded components made of a Polyvinyl Chloride (PVC)-rice hull composite material with a polymer capstock produced in White, Black or Weathered Wood color.

3.4. The guard system includes two identical rails used as both the top and bottom rail, vertical balusters, 5 inch x 5 inch post sleeves, Uni-Ball™ baluster connectors, rail to post brackets, support block, decorative moldings and post caps.

3.4.1. An extruded composite rail having an overall nominal sectional dimension of 3.30 inch wide by 2.28 inch tall is used for both the upper and lower rails. See Figure 1.

3.4.2. The baluster is extruded with a 1.40 inch square sectional profile and 0.160 inch wall thickness with chamfered corners. See Figure 2.

3.4.2.1. The balusters are secured to the top and bottom rail with 1.20 inch diameter Uni-Ball™ connectors. See Figure 4.

3.4.3. Top and bottom rails are attached to either conventional wood supports or a steel post-mount tower via 0.079 inch steel angle brackets. See Section 3.5.

3.4.4. A support block is installed between the lower rail and the deck surface midway between support posts. The single support block consists of a 1.40 inch square composite baluster cut to the appropriate length. It is attached to the bottom of the lower rail with a Uni-Ball™ connector.

3.5. Supports - Railing systems can be attached to conventional wood supports or a structural composite post installed with a steel post-mount tower.

3.5.1. Structural 5 inch by 5 inch composite posts are supported by either a UltiMount™ ProSpec or Enhanced Post Mount system as permitted by Table 2.

3.5.2. The 5 inch by 5 inch composite post sleeve can be utilized as a cladding over conventional 4x4 wood posts. See Figure 3.

4.0 Performance Characteristics

4.1. The guardrail system described in this report has demonstrated the capacity to resist the design loadings specified in Chapter 16 of the IBC and Section R301 of the IRC when tested in accordance with ICC-ES AC174.

4.2. Structural performance has been demonstrated for a temperature range from -20°F to 125°F.

4.3. Materials used are deemed equivalent to preservative treated or naturally durable wood for resistance to weathering effects, decay, and attack from termites.

4.4. The composite material used in the guardrail system has a flame spread index of 25 when tested according to ASTM E84. The referenced criteria of AC174 requires the material to have a flame spread index not greater than 200 when tested according to ASTM E84.

5.0 Installation

The guard system shall be installed in accordance with the manufacturer's installation instructions and this report. Where differences occur between this report and the manufacturer's installation instructions, this report shall govern.

5.1. The rail used for both the top and bottom rails is attached to the support post utilizing steel angle brackets.

5.2. The UltiMount™ ProSpec post mount system may be mounted in a wood deck. Installation in wood decks shall be in accordance with the manufacturer's installation instructions and Figure 6.

5.2.1. A minimum of four (4) anchor bolts must be used and located in the four (4) pre-drilled holes in the post base plate.

5.2.2. The anchors must have a minimum diameter equal to 3/8 inch.

5.3. The Enhanced Post Mount is mounted in a wood deck by direct attachment of the steel tube to the structural framing with two (2) 3/8 inch hex-head bolts. Placement of the post mount and the bolts shall be as shown in Figure 7. Design and construction of the supporting structural framing is not within the scope of this report.

5.4. The UltiMount™ ProSpec and the Enhanced Post Mount utilize a molded PVC extender (see Fig. 8) attached to the top of the steel tube with (2) #12 x 1" self-drilling / self-tapping screws. A solid 4x4 treated SYP wood block is inserted inside the PVC extender for attachment of the rail brackets when using the Enhanced Post Mount only.

5.5. Steel rail attachment brackets are shown in Figure 5. The top rail brackets utilize two (2) 0.25 inch by 2 inch lag screws and nylon washers for attachment to the post and two (2) 0.25 inch by 1.5 inch lag screws and nylon washers to secure the top rail to each bracket. The bottom rail brackets utilize two (2) 0.25 inch by 2 inch lag screws and nylon washers for attachment to the post and two (2) 0.25 inch by 1.5 inch long lag screws and nylon washers to secure the bottom rail to each bracket.

5.6. The baluster connections to both the top and bottom rails are made utilizing a Uni-ball™ connector at each attachment point. Each Uni-Ball™ connector is secured to the rail with a #8 by 2.25 inch long stainless steel self tapping flat head screw.

5.7. A single support block consists of a 1.38 inch square composite baluster cut to the appropriate length. It is attached to the lower rail with a #8 by 2.25 inch long stainless steel self tapping flat head screw passing thru the Uni-Ball™ connector and threaded into the underside of the lower rail.

5.8. The wood in the supporting structure, including conventional posts, shall have a specific gravity of 0.50 (southern yellow pine) or greater.

6.0 Supporting Evidence

6.1. Drawings and installation instructions submitted by the manufacturer.

6.2. The reports of testing and engineering analysis demonstrating compliance with the performance requirements of ICC-ES Acceptance Criteria for Deck Board Span ratings and Guardrail Systems (Guards and Handrails), AC174 effective June 2009,

6.3. The reports of testing and engineering analysis demonstrating compliance with the performance requirements ASTM D 7032-04, Standard Specification for Establishing Performance Ratings for Wood-Plastic Composite Deck Boards and Guardrail Systems (Guards or Handrails)

6.4. A quality control manual that is in accordance with the ICC-ES AC10, "Acceptance Criteria for Quality Documentation", approved February 2007, effective March 1, 2007.

7.0 Conditions of Use

The guard assemblies identified in this report are deemed to comply with the intent of the provisions of the referenced building codes subject to the following conditions.

7.1. Guardrail systems recognized in this report and regulated by the IBC or IRC are limited to exterior use in all construction types where wood is permitted in accordance with Section 1406.3 of the IBC and in One and Two Family Dwellings regulated by the IRC.

7.2. Uni-Ball™ connectors shall not be reused in the event that balusters or foot blocks are assembled over the Uni-Ball™ connectors and are then separated for any reason.

7.3. Conventional wood supports and supporting structural framing for guards are not within the scope of this report and are subject to evaluation and approval by the building official. Supports must satisfy the design load requirements specified in Chapter 16 of the IBC and must provide suitable material for anchorage of the rail brackets or support posts. Where required by the building official, engineering calculations and details shall be provided.

7.3.1. Structural support framing utilized for installation of the Enhanced Post Mount are not within the scope of this report and are subject to evaluation and approval by the building official.

7.3.2. Rim boards or band boards are not considered structural framing and posts or post-mount anchorage to these members is not an approved installation method unless specifically designed and constructed for anchorage of the guardrail posts.

7.3.3. Where required by the building official, engineering calculations and details shall be provided. The calculations shall verify that the anchorage complies with the building code for the type and condition of the supporting construction.

7.4. Compatibility of fasteners and other metallic components with the supporting structure, including chemically treated wood, is not within the scope of this report

7.5. *Traditional* Series guard systems are manufactured by GAF/Elk Composite Building Products Inc., in Lenexa, Kansas. Manufacturing is in accordance with an approved quality control system and inspections by Architectural Testing, Inc (AA-676).

8.0 Identification

The guard assemblies produced by GAF/Elk Composite Building Products Inc., identified in this report, shall be identified with labeling on the individual components or the packaging that includes the name and/or trademark of GAF/Elk Composite Building Products Inc, the name or identifying mark of the independent inspection agency, and the Architectural Testing Code Compliance Research Report Number (CCRR-0135) and mark.

9.0 Code Compliance Research Report Use

9.1. Approval of building products and/or materials can only be granted by a building official having legal authority in the specific jurisdiction where approval is sought.

9.2. Code Compliance Research Reports shall not be used in any manner that implies an endorsement of the product by Architectural Testing.

9.3. Reference to the Architectural Testing internet web site address at www.archtest.com is recommended to ascertain the current version and status of this report.

Table 1

Guardrail System	Guardrail Type	Code Occupancy Classification
91 inch by 42 inch <i>Traditional Series</i>	Level	IBC - (All Use Groups) IRC

Length dimensions are measured from inside of supporting posts.

Height dimensions are overall height from walking surface to top of guardrail

Table 2 – Post Mounts

<i>Post Mounting System</i>	Code Recognition	
	Maximum Supported Railing Length and Height ¹	
	IBC	IRC
UltiMount™ ProSpec	Use Group R3 & R4 only	91" Length 42" Height
Enhanced Post Mount	All Use Groups	91" Length 42" Height

¹ Railing lengths are clear length between supports. Railing height is installed height from walking surface to top of top rail.

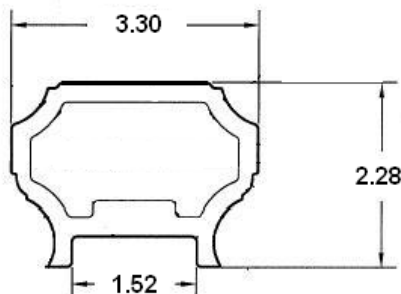

Figure 1
Rail Profile

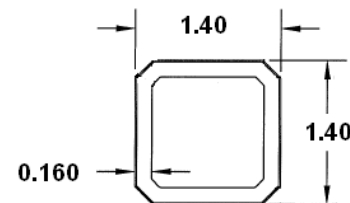

Figure 2
Baluster Profile

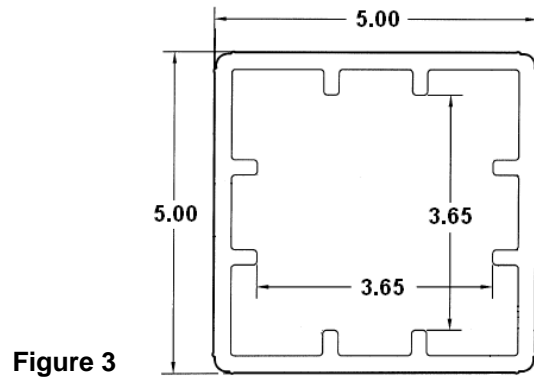
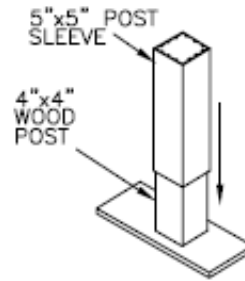
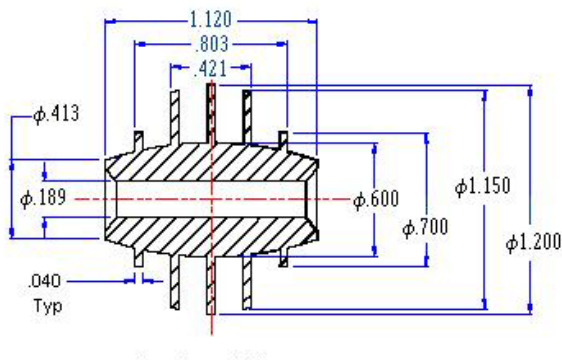

Figure 3



Composite Post Sleeve



**Sectional
Figure 4
Uni-Ball™
Baluster**

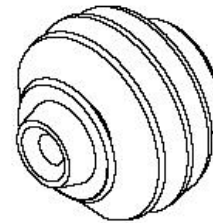

View

Connector

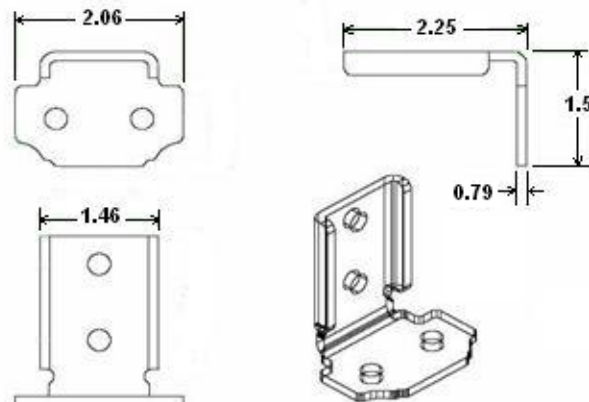

**Figure 5
Level Rail Bracket**

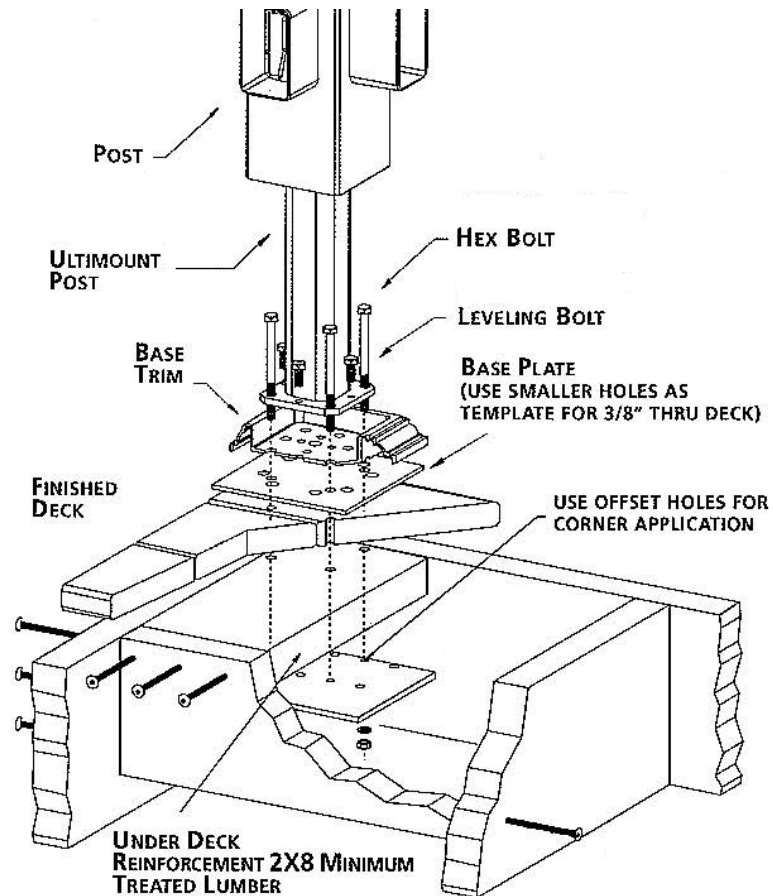

Note:

Cross supports and reinforcement shown are 2x8 Southern Pine (treated) or approved equivalent, fastened with #8 x 3" deck screws in the following quantities:
 (3) each end / each member
 (4) along supported edge of under deck blocking.
 Under deck blocking length is 14" minimum.

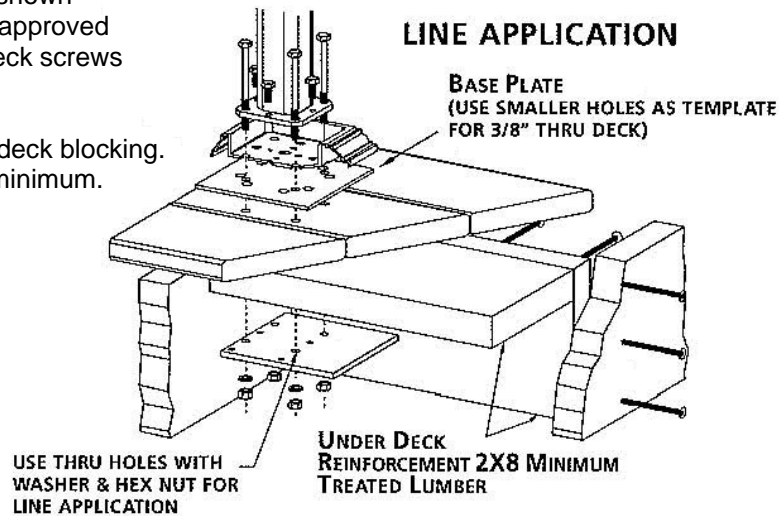

Figure 6 – UltiMount™ Installation on a Wood Deck

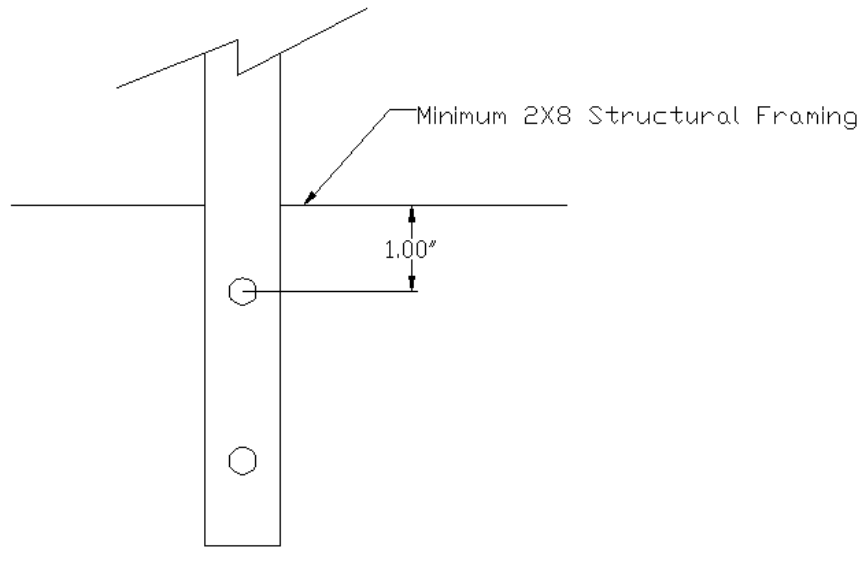

Figure 7 – Enhanced Post Mount Installation on a Wood Deck
(Railing is parallel with structural framing member)

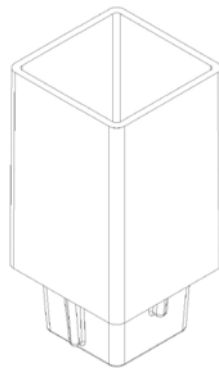

Figure 8 - Post Mount Extender (PVC)
Attaches to top of Ultimount™ ProSpec and Enhanced Post Mount